

THE LINK

> issue 1.0

news from the school of computer science

at **carnegie mellon university**



looking back



moving forward

FIFTY YEARS OF COMPUTER SCIENCE

< PLUS >

< THE POWER OF HUMANS >

< TEACHING CODING CONCEPTS WITH ALICE >

< A CURRENT LOOK AT CAMPUS AND FIVE ALUMNI IN THE SPOTLIGHT >

From the Dean



Welcome to the inaugural issue of *The Link*, the magazine from Carnegie Mellon University's School of Computer Science (SCS). We are sending this publication to the alumni, colleagues, parents and other friends who constitute the many personal connections our school has to the world. We plan to send this publication twice a year, so look forward to future issues.

Our use of the name *The Link* stems from two sources. First, it recognizes the pioneering work of our early founders, Allen Newell and Herb

Simon, in formulating the use of linked data structures for representing complex information. In 1956, along with J. C. Shaw of the RAND Corporation, they developed IPL, the first high-level language to support list data structures. This was but one step in their creation of the Logic Theorist, the first artificial intelligence program, also in 1956. Second, we want this publication to serve as an important link between you and the School of Computer Science. We are proud of the many people who have been connected to SCS over the years, and we want to keep that connection going.

This year, we are celebrating 50 years of computer science at Carnegie Mellon University. In the fall of 1956, the first computer, an IBM 650, was delivered to the basement of what was then the Graduate School of Industrial Administration at Carnegie Tech. This brought together Herb Simon, Allen Newell and Alan Perlis—they created a collaborative and innovative environment for computer science research and education that not only laid the groundwork for SCS but also has shaped many aspects of Carnegie Mellon University.

On April 20 to 22, 2006 we will celebrate CS50: Fifty Years of Computer Science at Carnegie Mellon with a program that highlights our accomplishments, shows off our research and educational activities, and imagines our future prospects. I would like to extend my personal invitation to each of you to attend this exciting event. A highlight of CS50 will be the "Gates Center Preview" in which we will make public the plans for our new building project, arising from a major gift from the Bill and Melinda Gates Foundation.

This issue of *The Link* is dedicated to the theme of CS50, looking back over the past fifty years of computer science at Carnegie Mellon University, and looking forward to what the next fifty years might bring. Enjoy!

> Randal E. Bryant, dean

< COVER STORY >



10 Fifty Years of Computer Science

What began with the vision of a new scientific frontier and one large computer has grown into the world-class School of Computer Science at Carnegie Mellon

< FEATURED ARTICLES >



8 Curiouser & Curiouser

Building student interest in computer science with a little inspiration from *Alice in Wonderland*



20 The Power of Humans

Linking “human processors” is more than just a game

2 Calendar of Events

3 In the News

4 Pittsburgh Campus Snapshot

6 Branch Campus Snapshots

7 In the Loop

Meet two of our distinguished faculty

14 Research Notes

15 Cool Things

Inspirations from SCS you can get your hands on today

16 SCS Alumni Relations

Hear from the director, learn about alumni gatherings

18 Alumni Spotlight

Meet five alumni that span the SCS semi-centennial

22 Robots Around the World

See some of the places Carnegie Mellon robots have been spotted

24 Faculty Awards

THE LINK

news from the school of
computer science at
carnegie mellon university

The Link provides a mosaic of the School of Computer Science: presenting issues, analyzing problems, offering occasional answers, giving exposure to faculty, students, researchers, staff and interdisciplinary partners. The Link strives to encourage better understanding of, and involvement in, the computer science community.

Editor-in-Chief

Randal E. Bryant, dean

Managing Editor/Writer

Joanna Steward

Contributing Writers

Tina Carr, Cheryl Collins Valyo

Photography

Ken Andreyo, Glenn Brooks, Ralf Brown,
Mary Shaw, Debra Tobin, University Archives

Design

Fitting Group

Printed by

Knepper Press
on 10% post-consumer recycled paper

Office of the Dean

4305 Newell-Simon Hall
Carnegie Mellon University
5000 Forbes Avenue
Pittsburgh PA 15213

Randal E. Bryant, dean

Cindy Chemsak, administrative assistant

Tina Carr, director of alumni relations

Anne Watzman, director of public relations

Joanna Steward, publications writer/editor

Deborah Harris, CS50 event coordinator

412-268-7884

TheLink@cs.cmu.edu

Carnegie Mellon University does not discriminate and Carnegie Mellon University is required not to discriminate in admission, employment, or administration of its programs or activities on the basis of race, color, national origin, sex or handicap in violation of Title VI of the Civil Rights Act of 1964, Title IX of the Educational Amendments of 1972 and Section 504 of the Rehabilitation Act of 1973 or other federal, state, or local laws or executive orders.

In addition, Carnegie Mellon University does not discriminate in admission, employment or administration of its programs on the basis of religion, creed, ancestry, belief, age, veteran status, sexual orientation or in violation of federal, state, or local laws or executive orders. However, in the judgment of the Carnegie Mellon Human Relations Commission, the Presidential Executive Order directing the Department of Defense to follow a policy of "Don't ask, don't tell, don't pursue" excludes openly gay, lesbian and bisexual students from receiving ROTC scholarships or serving in the military. Nevertheless, all ROTC classes at Carnegie Mellon University are available to all students.

Inquiries concerning application of these statements should be directed to the Provost or the Vice President for Enrollment, Carnegie Mellon University, 5000 Forbes Avenue, Pittsburgh, PA 15213, telephone 412-268-2000.

Carnegie Mellon University publishes an annual campus security report describing the university's security, alcohol and drug, and sexual assault policies and containing statistics about the number and type of crimes committed on the campus during the preceding three years. You can obtain a copy by contacting the Carnegie Mellon Police Department at 412-268-2323. The security report is available through the World Wide Web at www.cmu.edu/police/statistics.htm.

All rights reserved. No part of this publication may be reproduced in any form without written permission from the Office of the Dean, School of Computer Science.

Calendar of Events

All events to be held at the Carnegie Mellon University campus in Pittsburgh unless otherwise noted.

APRIL 20-22

CS50: Fifty Years of Computer Science at Carnegie Mellon
Spring Carnival and Buggy Races

MAY 9-10

How the Human Interface Can Make or Break Great Product Innovations
> Carnegie Mellon West

MAY 20

SCS Ph.D. Degree Ceremony

MAY 21

Carnegie Mellon University Commencement Ceremony

JUNE 20-21

RoboBusiness Conference & Expo (20-21) and
3rd Robot Hall of Fame Induction Ceremony (21)
> Sheraton Station Square, Pittsburgh

JUNE 25-29

23rd International Conference on Machine Learning

JUNE 26-AUGUST 4

Andrew's Leap (one six-week session for talented high school students)

JULY 12-14

Symposium On Usable Privacy and Security (SOUPS)

JULY 10-AUGUST 4

RoboCamp (four one-week sessions for middle school students)
> National Robotics Engineering Center, Pittsburgh

AUGUST 28

Fall 2006 Classes Begin

GRAND CHALLENGE SUCCESS



> H1ghlander



> Sandstorm

Despite a dramatic rollover that crushed its roof-mounted Riegl laser sensor, the 3-axis gimbal and much more just two weeks before the semi-finals, the Red Team's modified Hummer 'H1ghlander' won pole position and was the race favorite for the historic 2005 Grand Challenge autonomous vehicle race held on October 8, 2005 by the Defense Advanced Research Projects Agency (DARPA). Its sister vehicle, Red Team Too's veteran HMMWV 'Sandstorm', began in third position. Stanford Racing earned the number two spot with

'Stanley,' a turbocharged Volkswagen Touareg R5. Of the 195 teams who applied, 43 reached the semifinals and 23 saw the green flag on race day. Only five bots finished the 132-mile trek through the desert.

Red Team leader and SCS Professor William "Red" Whittaker chose to run two race strategies: Sandstorm was to steadily plod along well under its peak abilities, while H1ghlander's instructions were to run aggressively and finish first. Sandstorm was nearly perfect, finishing within two minutes of its plan, but in second place. Unfortunately, H1ghlander developed engine trouble and began falling away from its planned progress barely 30 miles into the contest. The distressed bot finished the race in 7 hours, 14 minutes—10 minutes behind Sandstorm, and 20 minutes behind Stanley, the winner of the \$2M prize.

If you look under Stanley's blue paint job, you might glimpse its plaid roots: the team is lead by former Carnegie Mellon SCS faculty member Sebastian Thrun, and gets its software expertise from Mike Montemerlo, an SCS 2003 Ph.D. graduate in robotics.

SPEECH-TO-SPEECH TRANSLATION

¿Hablas español? In the future, you might be able to speak Spanish or German, or even Chinese, without spending a single day learning those pesky irregular verbs.

In late October 2005, the International Center for Advanced Communication Technologies (InterACT), a joint project between Carnegie Mellon University and the University of Karlsruhe in Germany, unveiled a domain-independent speech-to-speech translation software development that can translate unscripted events with stunning accuracy. SCS Professor Alex Waibel wowed an international audience during the live joint German-American video news conference. Waibel spoke in English to the audience assembled at Carnegie Mellon while viewers in Karlsruhe heard his words in German seconds later. Simultaneously, a transcript in both Spanish and German was projected on the wall next to Waibel and his colleagues.

Google COMES TO PITTSBURGH

As part of their "worldwide effort to build engineering centers in locations where there are great engineers," Google plans to open an engineering center in Pittsburgh in 2006. Leading the venture is SCS Professor Andrew Moore, an expert in robotics and data mining.

"Andrew has built his career on the twin challenges of developing techniques to extract patterns from large data sets and applying these machine learning methods to real-life problems ranging from searching for distant asteroids to detecting possible bioterrorism incidents based on patterns of people buying over-the-counter medications," said SCS Dean Randy Bryant. "His talents line up well with Google's mission to 'organize the world's information and make it universally accessible and useful.'"

The Pittsburgh center is the latest addition to Google's growing number of facilities around the world, including Tokyo, Zurich, Bangalore, New York, Phoenix and Mountain View, California, where the company is headquartered.

SERIOUS GAMES GAINING GROUND

Two new video games from the Entertainment Technology Center (ETC) made a splash at the second annual Serious Game Summit in Arlington, Virginia last fall: PeaceMaker and Hazmat: Hotzone. An alternative to the entertainment-only approach, serious games allow players to actively participate as problem solvers, political leaders or humanitarian workers while also learning basic information that is normally, and passively, taught in textbooks or lectures. The event attracted more than 700 attendees from academe and industry.

PeaceMaker seeks to teach high school and college students about the complexities of the Israeli-Palestinian conflict, and instead of conquest and destruction, players try to achieve peace and cohabitation. An early version is expected to be released later this spring.

Hazmat: Hotzone is a simulation-based training tool for first responders developed in collaboration with the Fire Department of New York (FDNY). "Games make it possible to do knowledge- or cognitive-based training at a low cost without even having to leave the classroom," said project supervisor and ETC faculty member Jesse Schell.

The Entertainment Technology Center offers a master's program administered jointly by the College of Fine Arts and the School of Computer Science.



Pittsburgh Campus Snapshot

There's been a great deal of change on the Carnegie Mellon campus over the past 15 years: new classrooms, new dorms and even a new fence.

SCS Faculty

184 INDIVIDUALS including 36 post-doctoral fellows and 39 researchers

81% Male 19% Female

2005 SCS Undergraduates

539 ENROLLED from 20 different countries

77% Male 23% Female

Average Combined SAT: 1451

2005 SCS Graduate Students

Ph.D. Programs: 399 total enrolled

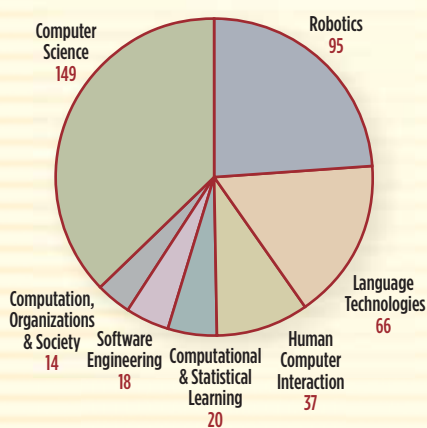

Master's Programs: 289 enrolled

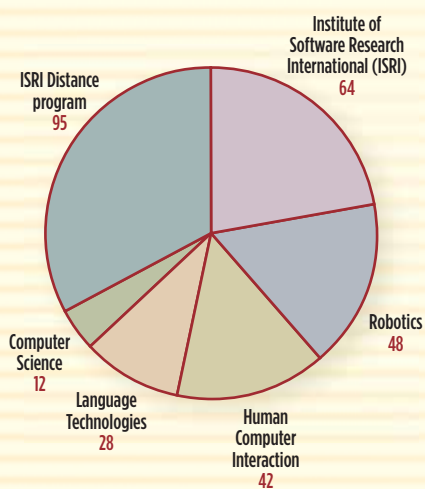

> University Center

Completed 1996

The UC's three levels include meeting spaces and offices for student groups, the Book Center & Art Store, U.S. Post Office and the Career Center, plus sports facilities like racquetball courts, a gym and aerobics rooms, and eating venues Andy's Corner, Skibo and the Koshers Korner. On the lower level is also Scotland Yard: a gaming area with pool tables, ping pong tables and video games.

> Residential Buildings

Resnick Hall & West Wing

Completed 1990

New House (LEED certified)

Completed 2003

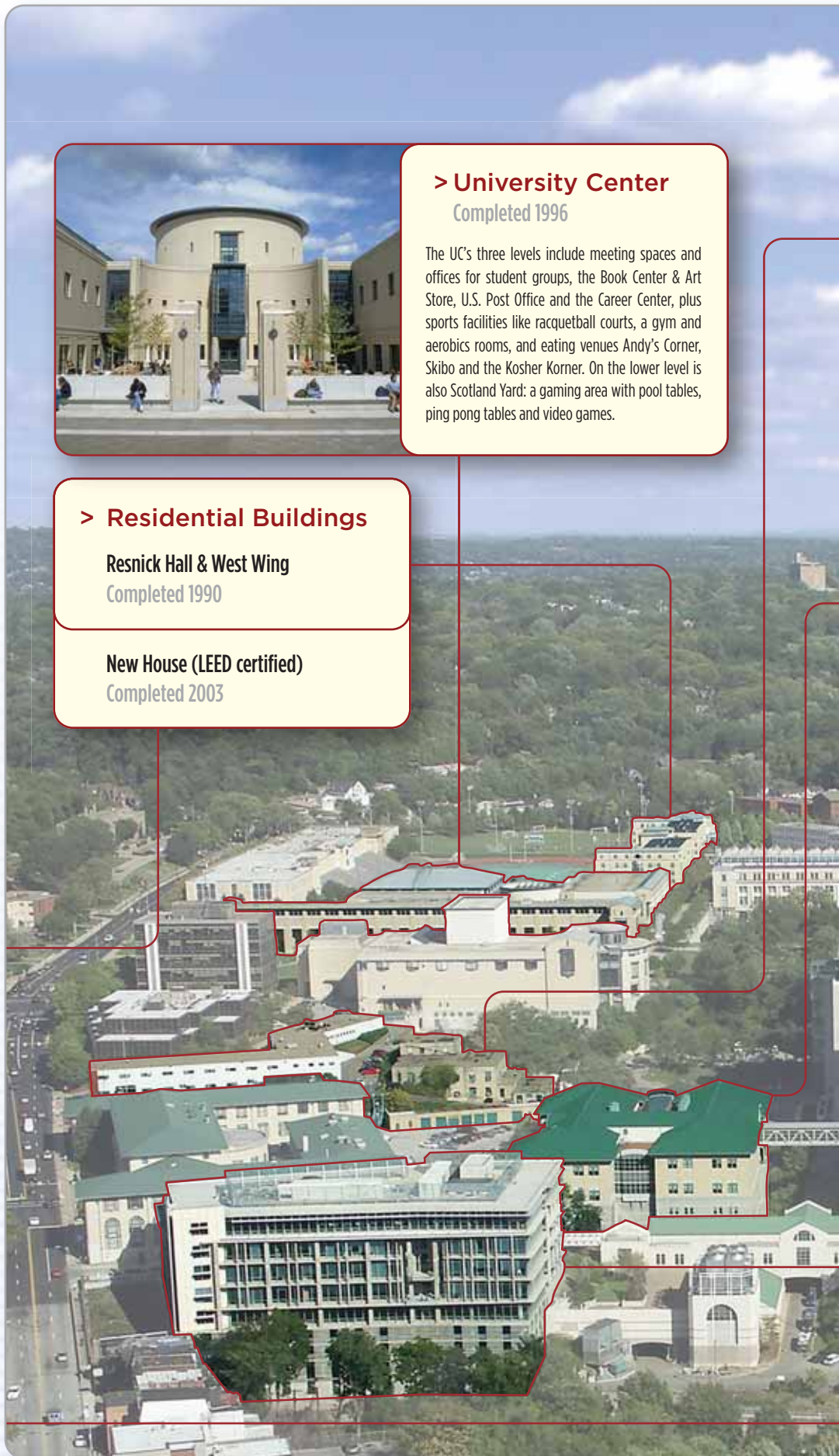

< STUDENT PROFILE >



This spring, SCS Junior **Stephanie Rosenthal** is taking a graduate class in the school of architecture. That might be something odd at any other school, but not at Carnegie Mellon. The Architectural Robotics class intersects Stephanie's interests in human-computer interaction, tangible interfaces and interactive spaces. She loves research and technology—so the diverse interdisciplinary program available through SCS is a perfect fit. "Students in the same major with the same computer science foundation can have interests from math and theory to AI to robotics to graphics and more," says Stephanie.

In addition to excelling at her studies, Stephanie is coordinator of the Little Sister/Big Sister program within Women@SCS, a peer-mentoring organization that has had a tremendous effect on attracting and retaining women in computer science. She is also the workshop chair for the fourth annual talent extravaganza, SCS Day, managing a score of students, faculty and staff who offer to share their knowledge and skills of areas outside of computer science—everything from knitting to magic tricks to karate.

On the heels of SCS Day, and thanks to a grant from the Office of the Dean, Stephanie and her fellow classmates will be hard at work on the very first SCS booth for Spring Carnival 2006 in April. Don't miss it!

Links:

<http://women.cs.cmu.edu>

www.cs.cmu.edu/~scsday

www.andrew.cmu.edu/org/carnival

> New Computer Science Complex

With 208,000 square feet over two buildings, 150 underground parking spaces and a great deal of pedestrian-friendly green space, the new computer science complex will transform the Carnegie Mellon campus and provide much needed space for computer science education and research. The contemporary buildings will replace four aging structures: the old student center, the Publications Building, the West Garages, and the Planetary Robotics Building. Plans call for demolition to begin in mid-March and for the project to be completed in late 2009.

The estimated cost of the overall project is \$88 million, with the Bill and Melinda Gates Foundation's gift of \$20 million securing the naming rights of the main building and providing inspiration for additional fundraising.

Artists' renderings and a scale model will be presented at a special preview ceremony on campus April 21 during CS50: Fifty Years of Computer Science at Carnegie Mellon. We hope you can join us.

Plans are underway for a live Web camera on the corner of Newell-Simon Hall so you can watch the transformation. Visit www.cs.cmu.edu for details.



> Newell-Simon Hall Completed 2000

Two former U.S. Bureau of Mines buildings were renovated inside and out, and connected with a glass-roofed atrium to form one unit. Inside are the SCS Office of the Dean, Robotics Institute, HCI, LTI, classrooms, an auditorium and two food vendors. An enclosed bridge links the new building to Wean Hall. The renovation was funded primarily through Carnegie Mellon's investment in Lycos, a pioneering search engine company formed by Micheal "Fuzzy" Mauldin (CS'83, '89).



> Collaborative Innovation Center Completed 2005

Built on the edge of Panther Hollow, this high tech building offers configurable dry lab space for industry partners utilizing a unique system of 'plug and play' floor panels and green design principles developed at Carnegie Mellon's Center for Building Performance Diagnostics. Current tenants include Intel and Apple.



> National Robotics Engineering Center Completed 1996

A high technology transformation of an existing industrial site alongside the Allegheny River, near the 40th Street bridge. Unusual site requirements included fields for testing agricultural robots, a pool for testing aquatic robots, and a robust system of fencing, including a "tank wall", to stop the occasional out-of-control robot.

Site for the upcoming CS50 Gala Reception on April 20, 2006.

Branch Campus Snapshots



< CALIFORNIA >

The Carnegie Mellon West campus was created in 1999 to strengthen the link between Carnegie Mellon and Silicon Valley, which has become the center of the computer industry. Over 160 mid-career professionals are enrolled in the two-year, part-time Master of Software Engineering program—most are employees of Silicon Valley companies like Google, IBM, Lockheed, eBay and Intuit.

“We’ve taken Carnegie Mellon’s learning-by-doing philosophy to the extreme. Virtually every course in the Software Engineering curriculum is based on a project that takes a team of several people about eight weeks to complete. Rather than sitting in lectures, each team meets with a faculty coach and several consultants and produces frequent deliverables equivalent to what they would produce in real jobs.”

> **Jim Morris**, dean, Carnegie Mellon West

Other initiatives include multi-day executive education classes, a summer robotics program for high school students, and various research projects supported by NASA, DARPA and Google.



< QATAR >

Carnegie Mellon University offers its top undergraduate programs in business and computer science at the new international branch campus in Doha, Qatar. Opened in 2004 at the invitation of the Qatar Foundation, students here follow the same demanding curriculum as their counterparts at the main campus in Pittsburgh, and they will earn the same prestigious degree. Classes are held in what’s known as Education City, a 2,400 acre campus on the outskirts of Doha with state-of-the-art learning and research facilities.

“If you visit us in Qatar, you’ll find lots of familiar things: the students may be wearing Arabic clothes, but they are sitting in the lounge, working on their 211 assignments, talking about how much homework they have and how excited they are to be at Carnegie Mellon (and how much they are looking forward to catching up on sleep at the next long weekend!) It really is a little corner of SCS located 6,000 miles away from the mother ship.”

> **Chuck Thorpe**, dean, Carnegie Mellon Qatar

You’ll also find SCS faculty from Pittsburgh teaching in Qatar. During the spring 2006 semester Mark Stehlik is teaching 15-113, Chuck Thorpe is the 16-100 instructor, and 15-100 is being led by LTI doctoral student Frank Lin.





JAIME CARBONELL

Allen Newell Professor of Computer Science
Director, Language Technologies Institute

On the value of language research:

“It is completely necessary in our current world. It’s necessary for commercial transactions, such as selling products abroad, or for conversing over the Web with someone who doesn’t speak your language. And it’s necessary for national defense. For example, one of the biggest problems has been that many materials related to suspected terrorism are in languages such as Arabic or Pashto that are not widely translated.

“Another important application is the preservation of minority and endangered languages. A hundred years ago there were about 9,000 languages spoken in the world. Estimates are that there will be about 3,000 at the end of this century. Languages are dying away. As a result, we are losing a lot of our linguistic diversity, our linguistic DNA, so to speak. We’ve done work with several minority languages, and the diversity of these languages is amazing. It is difficult to process them using purely statistical techniques, as you can with the vast amount of data available for major languages. We have chosen a machine learning approach to learn and preserve the structure of these lesser known languages.”

On new directions in language technologies:

“I’m very interested in computational biology, which involves treating biological sequences like DNA and primary protein sequences as though they are languages. They encode and transmit information and carry meaning. What we are doing is extracting that meaning. The ultimate goal is to understand the way proteins function, to help understand how a virus infects a cell in sufficient detail to block it at will. It is an emerging area and the technology shares a lot with language, even though the application is vastly different.”

On the artificial intelligence “family tree”:

“I am actually the first ‘second generation’ AI researcher. My father, Jaime R. Carbonell, was an acoustics engineer who became interested in artificial intelligence and eventually built the first large-scale computational tutor. I was nine when he brought our family from Uruguay to the United States.

“I came to Carnegie Mellon solely to work with Allen Newell and Herb Simon, to learn as much as I could and be part of the exciting work that they were doing. They’d already conducted their seminal work in AI and recruited me to work on natural language processing.”

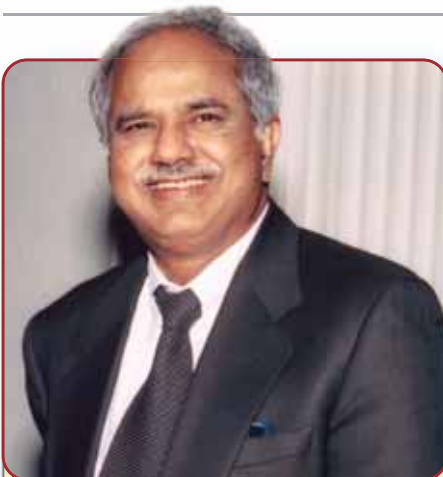

RAJ REDDY

Mozah Bint Nasser University Professor of
Computer Science and Robotics

On bringing computing power to those who have the least:

“My recent research is focused on how information technology can help poor and illiterate people. We tend to think that a person living in a remote village can’t use a computer because the technology is too complicated. But people will be able to use it if we design it right. The key thing is developing an ‘appliance model.’ A car is very complex, but you don’t need to figure out how it works to be able to drive it. The same should be true of a computer. It’s a matter of not only radically simplifying the user interface, but considering what people would use it for, such as communication or entertainment. Email might seem of little use to someone who can’t read. But email is just a symbol for a set of asynchronous communications. It doesn’t have to be written, it could be voice or video instead. The less literate the person, the more powerful, intelligent and cost-effective the computer must be.”

On the Million Book Digital Library Project:

“Content, such as books or entertainment, is another important area of research. The Million Book Digital Library is an international effort to digitize a million books by scanning and indexing their full text with OCR technology. In addition, we’ve made good progress toward the auxiliary goal of expanding computer memory cost-effectively—for this project we’ve been able to purchase large scale disks that provide 100 times the memory at a reasonable cost.”

On his return to the undergraduate classroom:

“After 15 years away from the classroom, I’m enjoying teaching again. I teach a project-based, autonomous mobile robot course to undergraduates as well as to high school students during the summer. I give them a broad background, historically what worked, what didn’t work in the development of robotics. For example, during the course of one lecture we’ll cover much of the area of computer vision. A lot of it might be over the head of a freshman, but the goal is to prepare them for future courses.”



CURIOUSER



CURIOUSER

Despite the complexity of problems facing our world, the thrill of advancing technology and the continued fruition of Moore's Law, computer science has lost some of its luster for the next generation. Universities across the nation, including Carnegie Mellon, are dealing with a significant four-year slide of student interest in, and applications to, their computer science programs. Although the School of Computer Science (SCS) received more than twelve applications for every available freshman seat in 2005, applications were nearly double that in 2001. While SCS isn't struggling to find talented students, as researchers, educators and leaders in the computer science community, it's prudent to explore the issue and formulate potential solutions.

So why is it, as computer technology becomes more embedded in our society, fewer young minds seem drawn to the challenges that still lie ahead? It's easy to blame the dot-com bust and the rise of outsourcing for the declining trend. However, a look upstream at the source of the intellectual pipeline points to another more intrinsic factor: the way computer science is taught in American high schools.

WRITING NAUGHT BUT CODE

According to many sources, the first drain on the pipeline is gender oriented: girls tend to opt out of science and math electives by the end of middle school. Next there is the geek factor. "Younger students often see computer science as something more like fixing people's computers than about identifying important problems in the world and looking for ways that technology can help," says Caitlin Kelleher, a computer science doctoral student at Carnegie Mellon.

Finally, there is the average high school introductory computer science class, which is often a frustrating experience in the joys of syntax and hours spent trying to master the programming language used by the College Board Advanced Placement test. It was C++ until 2003; today, it's Java. Notably absent in these early classes are the mathematical concepts and the human history of computer science, and their relevance in today's technological landscape. Learning to write code in this type of vacuum can drive students mad as a hatter and out of the pipeline completely.

But Kelleher and her advisor, SCS Professor Randy Pausch, may have found a way through the looking glass—an entertaining method to build student interest in the field of computer science while also teaching programming and problem-solving concepts.

WHO ARE YOU?

Meet Alice and her enormous cast of friends. Seat them around a table and they could quite literally be the Tea Party straight out of Lewis Carroll's *Alice in Wonderland*. Or perhaps a team of astronauts working in space. Or maybe a group of friends skating on a frozen lake.

Released in 2005, Alice 2.0 is a java-based open source story-telling environment where students create animated movies and simple video games using a drop-and-drag editor and visible data instead of detailed programming syntax. Alice makes the cognitive-to-perceptual leap with visual results to commands—students can watch their programs execute and actually see where they have made mistakes.

Best of all, Alice might just be the magic potion needed to grow the pipeline. Studies presented at the 2004 SIGCSE conference show that adding Alice to an introductory college-level programming course improves grades and dramatically increases the number of students who continue in the discipline. Pausch and Kelleher know of at least 60 universities and colleges utilizing the free Carnegie Mellon software, including Duke and Virginia Tech (which uses Alice for their entire freshman engineering class). Prentice Hall has printed an unprecedented 23,000 copies of its new introductory programming textbook *Learning to Program*

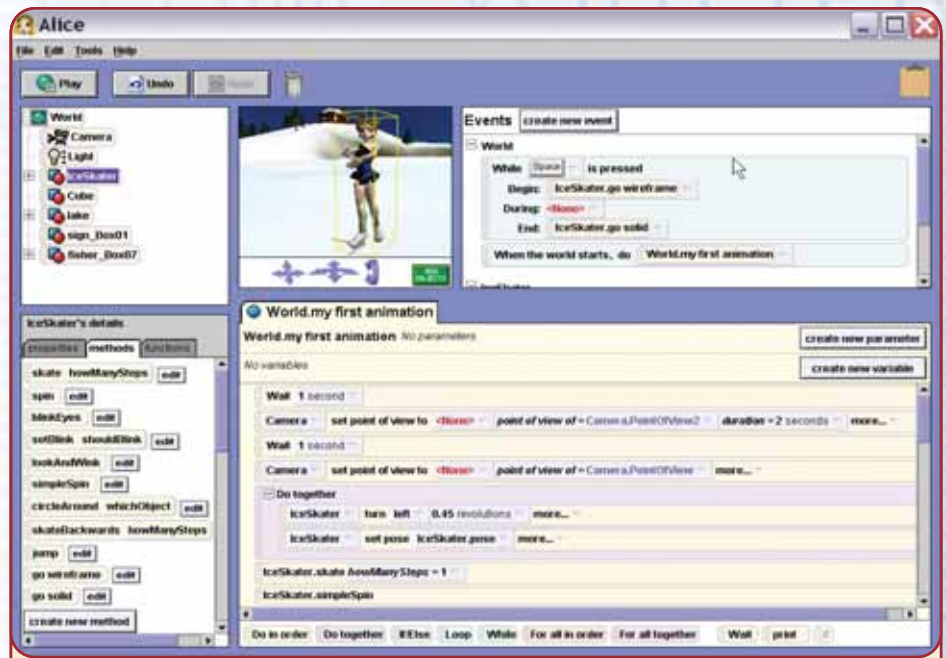

LOG ON > Visit www.alice.org to download your own Alice.

with Alice. The list of high schools using Alice has surpassed 50, and now industry is taking note, too: video game giant Electronic Arts (EA) recently became a major underwriter of the Alice project.

Electronic Arts will provide essential art assets from its popular PC video game, *The Sims*, which will transform Alice from a crude 3D programming tool into a compelling and user-friendly environment. "Getting the chance to use the characters and animations from *The Sims* is like

teaching at an art school and having Disney give you Mickey Mouse," Pausch explains. "*The Sims* is EA's 'crown jewel,' and the fact that they are willing to use it for education shows a kind of long-term vision one rarely sees from large corporations."

Alice 3.0 aims to power up the pipeline by appealing to a much broader and younger audience, namely middle school girls and boys. The new system will be able to gradually "remove the training wheels" to provide a smooth transition from the drag-and-drop Alice environment into the standard Java programming mechanisms as the students progress.

"I used to think that the motivation in using Alice was commanding the computer to do what you wanted," says Pausch, "Caitlin was one of the first to see that the user's motivation is really about story-telling." This important rubric will also be incorporated into Alice 3.0.

Not only does the story-telling approach appeal to virtually all age groups and demographics, it creates an experience that is germane to the student user. It can help them see the relevance of the underlying programming concepts and how those same concepts might be applied to real-life situations, integrated into tomorrow's technology and improved upon by future computer scientists. Δ



< **CAITLIN KELLEHER** >

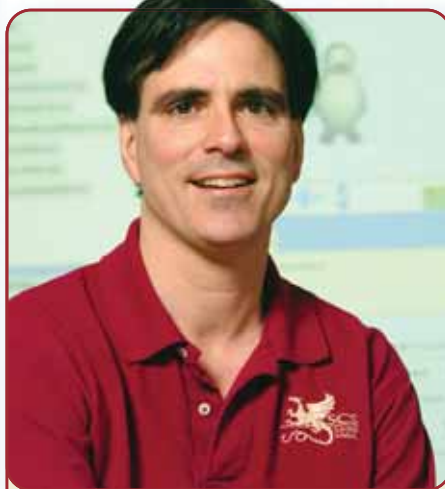

< **RANDY PAUSCH** >



FIFTY YEARS OF COMPUTER SCIENCE



LOOKING BACK

The very first computer on the tree-lined campus of Carnegie Institute of Technology was an IBM 650—a complex vacuum tube machine installed in a large room in the basement of the Graduate School of Industrial Administration (GSIA) building. The two piece console took up an entire wall. The card reader and independent power units were each the size of an upright piano. The 650 could crunch numbers for mathematics, solve least-squares problems for chemists, process flight data for air-traffic controllers and relieve scientists of tedious, time-consuming computational tasks. It calculated a thrilling few-thousand computations per second and was the centerpiece of Associate Dean Herbert Simon's new Computation Center.

It was 1956 and the decade that followed would see three Carnegie Tech visionaries shape the core of the computer science discipline as we know it today.

Herbert Simon joined the GSIA faculty in 1949 and was well known for cross-pollinating his research. His ground-breaking 1947 book, *Administrative Behavior*, looked at organizational decision-making through the filter of psychology and determined its effect on business economics (he would win the Nobel Prize in Economics in 1978 for this seminal work).

Allen Newell, a researcher at the RAND Corporation in California, joined Simon's "thinking machine" research at Carnegie Tech in 1955 and was awarded a Ph.D. degree in 1957. His work with the U.S. Air Force on radar maps proved that computers could do more than arithmetic.

Alan Perlis, a Pittsburgh native and 1942 Carnegie Tech graduate, possessed a passion for programming languages and problem solving. In 1956 he was chosen to head the Computation Center. He continued his work on the Internal Translator (IT) compiler and, in 1957, as chair of the Association for Computer Machinery committee charged with developing a common universal programming language, helped create ALGOL.

Simon and Newell (and J.C. Shaw still at RAND) were the vanguard of artificial intelligence. Together they proved that symbols could be substituted for numbers in computation and developed the Logic Theorist (LT), the only running program at the seminal 1956 Dartmouth summer workshop on AI. Both LT and its linked list processing language were formally presented to the research community at the Western Joint Computer Conference in February 1957.

Perlis meanwhile made the Computation Center at Carnegie Tech useful and available to the entire academic community, including the students in his 1958 freshman-level computer science course (the first in the nation).

As these men strove to expand the functionality of computing machines, the machines themselves were evolving. Changes in technology inspired new applications, which in return inspired research into newer technology. The study of computers and the phenomena surrounding them soon became very complex—and very controversial. There was a deep divide in the academic community over just what "computer science" entailed and whether or not it was even a true "science."

The trio of Simon, Newell and Perlis offered an eloquent public definition, and in doing so, set the compass for the future of computer science at Carnegie Mellon University:

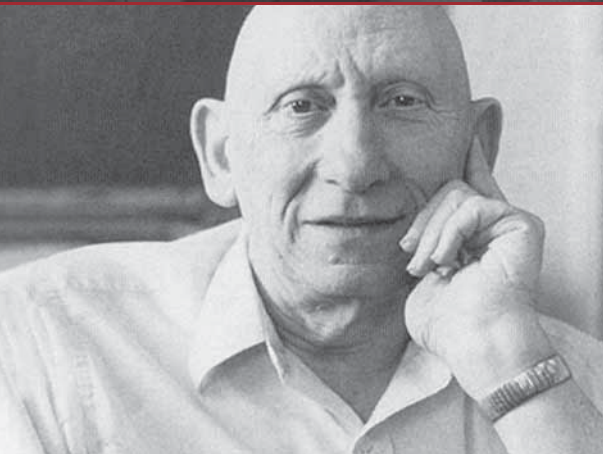
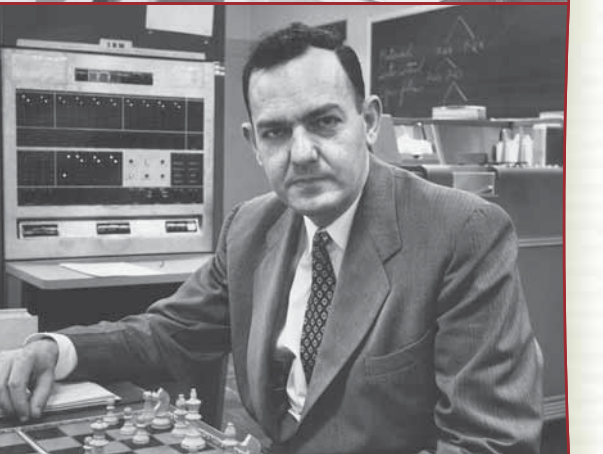

Letters

Professors of computer science are often asked: "Is there such a thing as computer science, and if there is, what is it?" The questions have a simple answer:

Whenever there are phenomena, there can be a science to describe and explain those phenomena. Thus, the simplest (and correct) answer to "What is botany?" is, "Botany is the study of plants." And zoology is the study of animals, astronomy the study of stars, and so on. Phenomena breed sciences.

There are computers. Ergo, computer science is the study of computers. The phenomena surrounding computers are varied, complex, rich. It remains only to answer the objections posed by many skeptics.

Objection 1. Only natural phenomena breed sciences, but computers are artificial, hence are whatever they are made to be, hence obey no invariable laws, hence cannot be described and explained.

Answer. 1. The objection is patently false, since computers and computer programs are being described and explained daily. 2. The objection would equally rule out of science large portions of organic chemistry (substitute "silicones" for "computers"), physics (substitute "superconductivity" for "computers") and even botany (substitute "hybrid corn" for "computers"). The objection would certainly rule out mathematics, but in any event its status as a natural science is idiosyncratic.

Objection 2. The term "computer" is not well defined, and its meaning will change with new developments; hence

computer science does not have a well-defined subject matter. **Answer.** The phenomena of all sciences change over time; the process of understanding assures that this will be the case. Astronomy did not originally include the study of interstellar gases; physics did not include radioactivity; psychology did not include the study of animal behavior. Mathematics was once defined as the "science of quantity."

Objection 3. Computer science is the study of algorithms (or programs), not computers. **Answer.** 1. Showing a deeper insight that they are sometimes credited with, the founders of the chief professional organization for computer science named it the Association for Computing Machinery. 2. In the definition, "computers" means "living computers"—the hardware, their programs or algorithms, and all that goes with them. Computer science is the study of the phenomena surrounding computers. "Computers plus algorithms," "living computers," or simply "computers" all come to the same thing—the same phenomena.

Objection 4. Computers, like thermometers, are instruments, not phenomena. Instruments lead away to their user sciences; the behaviors of instruments are subsumed as special topics in other sciences (not always the user sciences—electron microscopy belongs to physics, not biology). **Answer.** The computer is such a novel and complex instrument that its behavior is subsumed under no other science; its study does not lead away to

user sciences, but to further study of computers. Hence, the computer is not just an instrument but a phenomena as well, requiring description and explanation.

Objection 5. Computer science is a branch of electronics (or mathematics, psychology, and so forth). **Answer.** To study computers, one may need to study some or all of these. Phenomena define the focus of a science, not its boundaries. Many of the phenomena of computers are also the phenomena of some other science. The existence of biochemistry denies neither the existence of biology nor of chemistry. But all of the phenomena of computers are not subsumed under any one existing science.

Objection 6. Computers belong to engineering, not science. **Answer.** They belong to both, like electricity (physics and electrical engineering) or plants (botany and agriculture). Time will tell what professional specialization is desirable between analysis and synthesis, and between the pure study of computers and their applications.

Computer scientists will often join hands with colleagues from other disciplines in common endeavor. Mostly, computer scientists will study living computers with the same passion that others have studied plants, stars, glaciers, dyestuffs, and magnetism; and with the same confidence that intelligent, persistent curiosity will yield interesting and perhaps useful knowledge.

ALLEN NEWELL
ALAN J. PERLIS
HERBERT A. SIMON

*Graduate School of Industrial
Administration, Carnegie Institute
of Technology, Pittsburgh,
Pennsylvania 15213*



MOVING FORWARD

In 1977, at the 10th anniversary celebration of the Computer Science Department (CSD), Alan Perlis pointed out how their letter to *Science* magazine still held true:

“Some years back in the publication that I hope my name will be bound most closely to, Herb Simon, Al Newell and I submitted a letter to Science magazine in which we said what computer science was. And in our confessed ignorance, we said it had to be the study of phenomena arising around computers. We were right then, we’re right today and I think we’ll be right twenty years from now. The computer should make us all humble because it is not possible for any of us, no matter how bright we are, or what our experience, to predict what it is going to be used for. It may ultimately disappear and be hidden under all kinds of gadgets and never be seen again, like the electric motor, and our only memories of the computer will be abstractions—things we talk about, thing we draw, music we play. Who knows? But to say that computer science is [only] artificial intelligence, or complexity theory, or programming languages, or operating systems or what-not, is ridiculous.”



Today, the School of Computer Science at Carnegie Mellon University is one of the largest, broadest and strongest information technology research organizations in the world.

The non-restrictive view of the computational world described by Simon, Newell and Perlis opened doors between researchers and faculty, between faculty and students, between disciplines and between institutions. It promoted growth in an entrepreneurial fashion—researchers could follow their passions and their inspirations without needing to fit within a narrow definition of computer science. Seeds of a concept could sprout into discussions and collaborations of any configuration, the growth of which was governed by the interest it generated.

Simon and Newell embodied the process themselves. They looked beyond the limited computing power and the machine language of the IBM 650. To them, it was an early prototype of what would one day become intelligent machines: man-made systems that would emulate, augment and extend the human intellect. They made the “big bet” that they were right and they dedicated their careers to the nascent field of artificial intelligence.



Carnegie Mellon faculty, researchers and alumni throughout the past 50 years have followed in their footsteps, creating impact through innovation and inspiration.

> **Academic leadership.** The university placed a “big bet” on the future of the discipline and created one of the first academic departments in the nation dedicated to the study of computer science. (The Computer Science Department evolved into SCS in 1988.)

> **Multiprocessor parallel computer systems.** C.mmp and C.m* (“c-m-star”) showed that constructing large systems from smaller commodity components could track the tremendous economies of scale to come.

> **A serious game with chess-playing computers.** The Hitech machine, with its unique approach to generating all possible moves for each square, eventually achieved grandmaster status. Work at SCS continued the bet with Deep Thought and contributed to Deep Blue, the machine that finally beat Garry Kasparov in 1997.

> **Making systems more reliable.** Symbolic model checking vastly improved the scale of systems that could be verified, and proof-carrying code provided a simple way to confirm that downloaded data could be trusted.

> **Robots, every kind imaginable.** Beginning with the Direct Drive Arm that revolutionized industrial robotic operations, to hopping robots, to the incredible success of Sandstorm and H1ghlander, Carnegie Mellon remains a leader in this field.

> **Finding the World Wide Web.** The evolution and widespread use of the Internet spawned research into how to easily access the enormous amount of information available. The Lycos search engine led the way; Vivisimo followed with a more focused “niche finding” approach.

> **Current SCS research spans** across nanotechnology, game theory, computational biology, redesigning the Internet, human-computer interaction and more.

Note: The full list of SCS achievements is incredibly rich and complex. Look for future articles in The Link to present some of these achievements in greater depth.

While the technological and scientific achievements born at Carnegie Mellon are truly significant, so is the academic mission of SCS—to develop the next generation of leaders in computer science and information technology. The curriculum is rigorous, the hours required are long and the faculty is committed, but its reward is that alumni continue to grow and learn and reinvest in the discipline.

“One can only display complex information in the mind. Like seeing, movement or flow or alteration of view is more important than the static picture, no matter how lovely.” — Alan Perlis

It’s a good bet that the next 50 years of computer science at Carnegie Mellon will be as amazing as the first. Δ

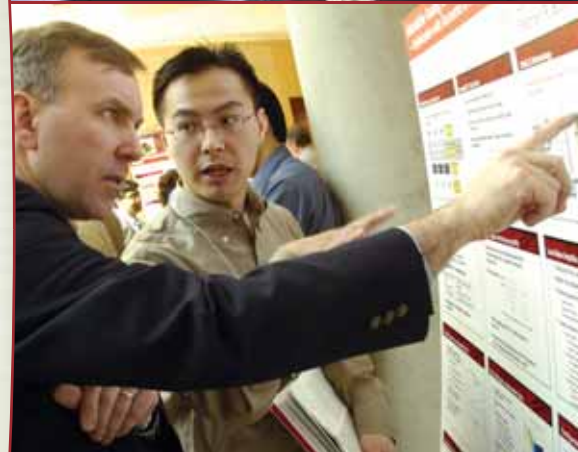

The School of Computer Science will host a campus-wide celebration April 20-22, 2006 to commemorate past achievements and to celebrate future endeavors that will continue to revolutionize the world. Key events include a semi-centennial symposium, remembrances by some of the computer science pioneers at Carnegie Mellon (“Voice of the Titans”), an evening reception gala at the NREC facility and a special preview of the new Gates Center for Computer Science.

Register today at www.CS50.cs.cmu.edu !

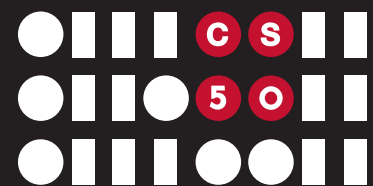

Carnegie Mellon
FIFTY YEARS OF COMPUTER SCIENCE

Research Notes

SUBCELLULAR IMAGES

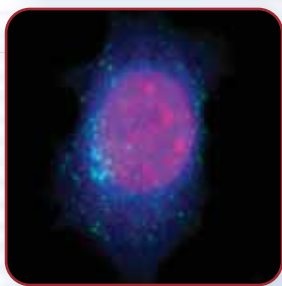
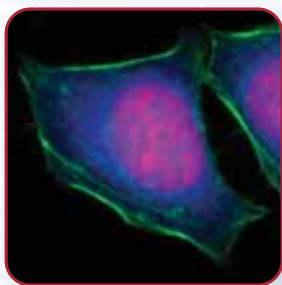

Computational biology is an active area of research at Carnegie Mellon, with emphasis on the application of machine learning and data mining techniques to large biological knowledge bases, biological modeling, computational aspects of high-throughput laboratory methodologies for large-scale, systematic studies of protein structure and function, analysis of biological image data and computational genomics.

SCS Professor Robert Murphy and Associate Research Professor William Cohen are developing the Subcellular Location Image Finder (SLIF), which finds fluorescence microscope images in

online journal articles and indexes them according to the cell line, the proteins visualized and the resolution, and then stores the information in a Web-accessible database. (Z. Kou, J. Hua and M. Joffe)

PERVASIVE COMPUTING

Over the past five years, the MyCampus group has been developing and experimenting with ambient intelligence technologies aimed at enhancing everyday life. The project has drawn on multiple areas of expertise, combining the development of an open Semantic Web infrastructure for context-aware service provisioning with an emphasis on issues of privacy and usability. A central element of this infrastructure is a semantic e-wallet that can provide contextual information (e.g. calendars, location tracking, relevant user preferences, organizational databases) while also enforcing privacy preferences. Prototypes have been tested on the Carnegie Mellon campus, in several office applications and as a tour guide for a Taiwan museum. (Ambient Intelligence: The MyCampus Experience by N. Sadeh, F. L. Gandon and O.B. Kwon)



MUSIC TO YOUR EARS

SCS Associate Professor Roger Dannenberg and his students are developing new techniques for “machine listening” that allow computers to make sense out of musical signals. The “Score-align” program can match audio recordings to the symbolic data (lists of musical notes) found in MIDI files, and could prove useful for recording engineers and music education. (N. Hu, G. Tzanetakis, J. Hailpern and W. Haines)

MORE THAN MODELING CLAY

Claytronics is a form of programmable matter, a system of individual units which act as a coherent mass to mimic, with high-fidelity and in three-dimensional solid form, the look, feel and motion of macro-scale objects. SCS Associate Professors Seth Goldstein and Todd Mowry and an interdisciplinary team of colleagues are investigating the design and manufacture of the individual units, called claytronic atoms (or catoms), and the methods to control the ensemble by programming the individual catoms so that they can self-assemble into arbitrary dynamic 3D objects.

A potential early application of the technology is the construction of programmable antennas that can change shape and radio characteristics on demand, under software control. Using magnets and ball bearings to stand in for spherical catoms, Goldstein demonstrated various antenna characteristics at the Intel Research Pittsburgh Lab open house last October and again this past January when the U.S. secretary of commerce visited campus.



RETHINKING DISKS

Researchers from Carnegie Mellon’s Parallel Data Lab, Intel Research Pittsburgh and EMC Corporation were recently awarded Best Paper at the 2005 File and Storage Technologies (FAST) conference, the top forum for storage systems research. Entitled “On Multidimensional Data and Modern Disks”*, the paper showed that the characteristics of modern hard disk drives can allow for efficient access of multidimensional datasets, such as those used in databases, earthquake simulation and scientific computing, and challenged decades of conventional wisdom that hard disk drives can only efficiently access one-dimensional datasets. (*S. W. Schlosser, J. Schindler, S. Papadomanolakis, M. Shao, A. Ailamaki, C. Faloutsos and G. R. Ganger)

BIG BEN

January 17, 2006 marked the 300th anniversary of Benjamin Franklin's birth and a new Web portal based on Vivisimo's clustering technology now offers a way to separate useful Franklin facts from the normal flood of online information. Developed by several Carnegie Mellon alumni, the underlying search algorithms filter and index results to create clusters that are easier to navigate than a long list of Web page "hits."

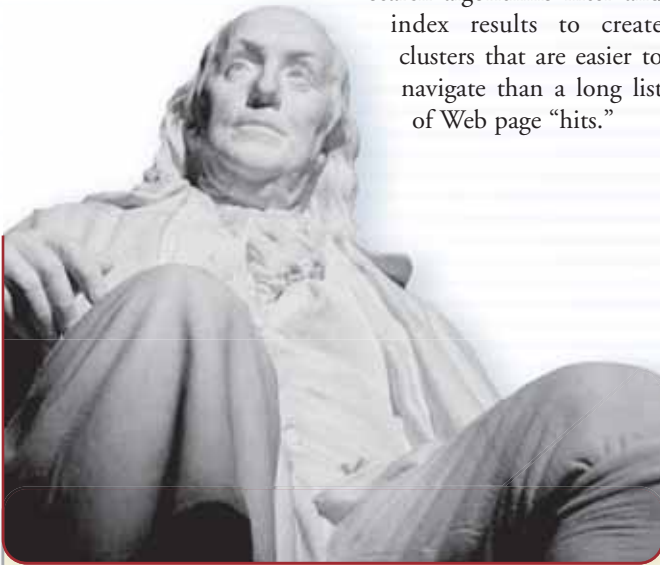

LOG ON > <http://ben.clusty.com>

PEER-TO-PEER-TO-PEER

End System Multicast (ESM) is an exciting technology which enables anyone on the Internet to broadcast high-quality video and audio from their desktop computer to a large number of users. Using a peer-to-peer network to distribute the content streams to all participants in the broadcast, when you tune in, you are both downloading the stream and uploading it to other people who are watching at the same time.

LOG ON > <http://esm.cs.cmu.edu>

If you can't attend CS50 in April, join in via ESM.

PATH OF DESTRUCTION

Software developed by scientists at Carnegie Mellon and NASA's Ames Research Center allows Internet users to see detailed views of the destruction wrought by Hurricane Katrina. More than 7,300 aerial photos taken of the Gulf Coast by the Remote Sensing Division of the National Oceanic and Atmospheric Administration (NOAA) have been overlaid onto Google Earth using Carnegie Mellon's software.



LOG ON > Mapping software:
<http://earth.google.com>

Overlays for Hurricanes Katrina, Rita & Wilma:
<http://jaga.gc.cs.cmu.edu/noaa>

Global Connection:
<http://www.cs.cmu.edu/~globalconn/katrina.html>

RECENT BOOKS:



**Security and Usability:
Designing Secure Systems
that People Can Use**

Edited by SCS Professor Lorrie Cranor
and Simson Garfinkel



**How to Survive a Robot Uprising:
Tips on Defending Yourself
Against the Coming Rebellion**

by Daniel H. Wilson (CS'05)

SCS Alumni Relations



FROM THE DIRECTOR

Welcome to *The Link*, a valuable resource for our alumni and friends to keep in touch with the School of Computer Science. Each edition will include a section dedicated to sharing with you the latest alumni news, highlights of recent events and examples of how our alumni are staying involved.

As a graduate, you have the opportunity to help current students have a better experience at Carnegie Mellon by volunteering your time and energy to the school and to the university. Serving as a company recruiter, mentoring a student, organizing an alumni event, participating on an alumni committee or meeting with prospective students in various cities are just some of the ways you can make an impact. Even attending alumni events in your region helps support your school and provides opportunities to network with fellow alumni and future graduates. If you have another idea on how you would like

to be involved with the School of Computer Science, I would be happy to talk with you and customize a volunteer opportunity.

One example of alumni volunteer efforts that have been making a difference is the SCS Alumni Advisory Board (AAB). Formed in 2001, the AAB is a committee of undergraduate and graduate alumni and student representatives that assists the school in developing initiatives to foster and strengthen relationships between alumni, students and the school.

The AAB helped establish the SCS Alumni Award for Undergraduate Excellence in Computer Science in 2003. Presented during the SCS graduation ceremony in May, this annual award recognizes multiple facets of excellence in student research. Projects are evaluated on the thesis and both oral and poster presentations. Recipients include Scott Nieuikum (CS'05), Bernice Ma (CS'04) and Kayvon Fatahalian (CS'03), who is now a member of the AAB. "The biggest impact the award had on me was to make me aware of the presence and interest of the alumni community. As an award recipient, I was excited to help with the judging of the award the following year and that's how I became involved with the AAB. I enjoy having the opportunity to use my experiences at Carnegie Mellon to help improve that of others," says Fatahalian.

Our alumni are making a difference and enhancing the Carnegie Mellon experience for future graduates. Whether it's simply offering advice on careers or graduate school, making a job contact or just sharing what you would or wouldn't have done differently, you can make a difference today.

As you can see, our alumni are very important to us and we want to continue to keep you connected to SCS, inform you about the latest news and events and ensure you learn about the many opportunities to stay involved. To do this, we need your current contact information. Please visit the Carnegie Mellon alumni Website at <http://alumni.cmu.edu> or send email to tcarr@cs.cmu.edu when your email address or other information needs to be updated.

I welcome any feedback, comments or suggestions; please feel free to send me an email anytime. I hope to see you at the CS50 Anniversary Celebration in April!

Tina M. Carr (HNZ'02)
Director of Alumni Relations

SCS ALUMNI AT-A-GLANCE

TOTAL ALUMNI: 3,735
3074 Male 661 Female

Alumni by Geography

Top Six Locations

DOMESTIC

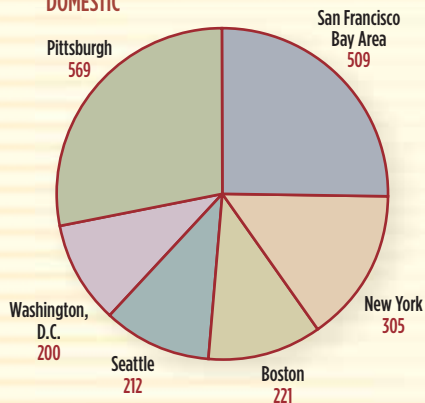

INTERNATIONAL

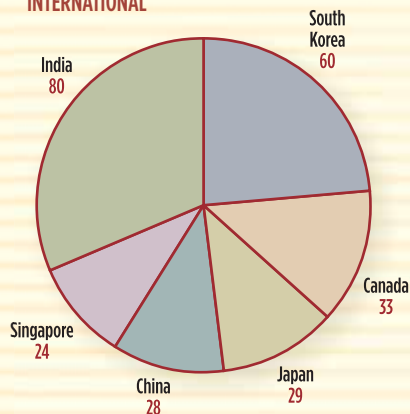

The 2004-2005 AAB members gather in the Perlis Atrium of Newell-Simon Hall during the 2005 Spring Meeting.



Row 1: Chris Maeda (CS'92, '97), Ting Shih (CS'01, '04), Jennifer Li (CS'04), Andrew Dubois (CS'03), Amy Matzke (CS'07), Monte Zweben (CS'85), Grace Lewis (CS'01), Bernardine Dias (CS'00, '04)
Row 2: Phil Bronner (CS'92), Eric Daimler (HS'94, CS'08), Brad Chen (CS'94), Jonathan Betz (CS'99), Kate Libby (CS'06), David Steier (CS'86, '89), David Murray (CS'06), Philip Lehman (CS'78, '84), Scott Russell (CS'82)
Not Pictured: Jonathan Goldick (S'88, E'89), Sesh Iyer (CS'96), Denise Noyes (CS'04), Todd Rockoff (CS'90, '94), Steven Shafer (CS'79, '83)

ALUMNI EVENTS

In 2005, SCS alumni events were held in New York City, and jointly with ECE in Seattle, Austin and San Francisco.

New York City

Marc Donner (CS'82, '84) and his wife, Ronnie Halper, hosted an alumni reception at their home on November 17, 2005. Over 40 SCS alumni attended, including special guest Mark Stehlik, assistant dean for undergraduate education.



Hosts Ronnie Halper and Marc Donner (CS'82, '84)



Left to right: Calvin Kim (CS'96), Jennifer Li (CS'04), Michael Blain (CS'04) and Lacey Neagle (CS'04)

2005-2006 ALUMNI ADVISORY BOARD

* co-chairs

- Jonathan T. Betz (CS'99)
- Philip L. Bronner (CS'92)
- J. Bradley Chen (CS'94)
- Eric A. Daimler (HS'94, CS'08)
- M. Bernardine Dias (CS'00, '04)
- Andrew Dubois (CS'03)
- Kayvon Fatahalian (CS'03)
- Jonathan S. Goldick (S'88, E'89)
- Sriram Gollapalli (CS'02, MISM'03)
- Seshadri Iyer (CS'96)
- Ajay Jain (CS'91, '92)
- *Philip L. Lehman (CS'78, '84)
- Grace A. Lewis (CS'01)
- Jennifer Li (CS'04)
- Chris M. Maeda (CS'92, '97)
- Raúl Medina-Mora (CS'79, '82)
- Wil Paredes (CS'01, MET'01)
- *Todd E. Rockoff (CS'90, '94)
- Scott Russell (CS'82)
- Ting Chih Shih (CS'01, '04)
- David M. Steier (CS'86, '89)
- Monte Zweben (CS'85)

Student Representatives

- Kate Libby (CS'06)
- Amy Matzke (CS'07)
- David Murray (CS'06)
- Allison Rozwat (CS'07)

To learn more about the board and its members visit www.cs.cmu.edu/alumni/AAB

Alumni Spotlight



J. RENATO ITURRIAGA

B.S., Physics & Astronomy
National University of Mexico, 1963

M.S., Mathematics
Carnegie Institute of Technology, 1964

Ph.D., Computer Science
Carnegie Institute of Technology, 1967

In 1960 Renato Iturriaga took a break from his undergraduate studies at the National University of Mexico to spend a few months as a visiting programmer in the Computation Center at Carnegie Institute of Technology. At the encouragement of his mentor, Alan Perlis, he returned in the fall of 1963 and went on to earn one of the first computer science-specific Ph.D.s granted from what is now Carnegie Mellon University. His 1967 dissertation, Mechanical Mathematics, was a mixture of language design, compiler writing, formal proof, artificial intelligence and heuristic algorithms.

Armed with the broad “systemic-thinking approach” of Simon, Newell and Perlis, Renato spent the first ten years of his career in academics, moved on to the banking industry for his second decade, and finally became involved in the Mexican government. Renato is currently head of the Special Unit for Priority Programs Monitoring in the Mexican Ministry of

Health and monitors a dozen federal priority health programs for “turbulence analysis” or unexpected deviations.

“ On an intellectual level, I enjoy first to understand the forces, or drivers, that move things in some direction. Then, I enjoy the challenge to find out clever ways to use that understanding to push, or to stop, things to happen. On the ethical level, I am deeply satisfied working on projects in which success means reduction of mother and children mortality, or better medical care to under-privileged people.”

He currently lives just outside Mexico City with his wife, Mariana, daughters Mariana and Ximena and their German Shepard, Leo.

His Pittsburgh favorites: wine and cheese gatherings in Mudge Hall organized by the European graduate students and symphony concerts at the Syria Mosque.



ANITA JONES

B.S., Mathematics
Rice University, 1964

M.A., English Literature
University of Texas, 1966

Ph.D., Computer Science
Carnegie Mellon University, 1973

A willingness to branch out in all directions and to continually learn new things has led Anita Jones down quite a number of interesting paths. Equipped with degrees in mathematics and English literature, Anita found her stride in the Computer Science Department at Carnegie Mellon University. She flourished amid the unique blend of nurturing and competition between faculty and students, earned a Ph.D. with her thesis on the importance of network security and then joined the faculty as an assistant professor.

In 1981 she took a turn in the business of computer science. She co-founded Tartan Laboratories, a software research company, with her colleague and husband Bill Wulf (CS’99, honorary).

Along the way, Anita became involved in various Department of Defense (DoD) advisory boards and organizations. In 1993, she was appointed by President Clinton as director of defense research and engineering, a position just two levels

below the secretary of defense and one of the highest to be held by a woman. Anita returned to teaching in 1997 at the University of Virginia (UVa) where she had been chair of the computer science department from 1988 to 1993.

“ At Canegie Mellon I learned that if you work on important and hard problems, you are rewarded with the opportunity to work with some of the best, most interesting people on the planet.”

Anita’s curriculum vitae includes many unusual experiences, too: a visit to the South Pole, a trek underwater in a Trident submarine, a jolting stop in an arrested landing of a fighter plane on an aircraft carrier and a free fall after a jump from a parachute training tower.

Anita continues to teach computer science and technology policy at UVa and to advise governmental and industrial organizations. She also enjoys perennial flower gardening.



STEVE MINTON

B.A., Psychology
Yale University, 1980

M.S., Computer Science
Carnegie Mellon University, 1983

Ph.D., Computer Science
Carnegie Mellon University, 1988

Steve Minton's work embodies the diversity of artificial intelligence. As a graduate student at Carnegie Mellon, he researched machine learning algorithms. After earning his Ph.D., he switched gears, joined NASA and contributed new AI approaches to a wide range of applications, including the Hubble Space Telescope scheduler. A return to academic research at the University of Southern California led him to his current foray into cyberspace: Steve is co-founder (with Craig Knoblock, CS'91) of Fetch Technologies, a Web intelligence company headquartered in Marina Del Rey, California.

"I love what I do. I have the opportunity to work with some very smart people, and see new AI and machine learning technology put into practice."

In 1993, Steve founded the Journal of Artificial Intelligence Research (JAIR), one of the leading journals in AI, and served as its first executive editor. He also founded the AI Access Foundation, and currently serves on its board of directors.

As a student in Pittsburgh, he lived in the 'House of Seven Grads'—today he lives in Southern California with his wife, Bernadette Kowalski Minton (CS'89), and their two children.



IAN LANE DAVIS

B.S., Computer Science, English, Math
Dartmouth College, 1991

Ph.D., Robotics
Carnegie Mellon University, 1996

These days when Ian Davis walks into a video game store, he's likely to see one of his own creations on the shelf. Davis founded Mad Doc Software in 1999 to develop Triple A titles that make creative use of new networking, graphics and AI technologies. His credits, so far, include Empire Earth II® (a PC Gamer Editor's Choice award winner) and Dungeon Siege: Legend of Aranna™ (an Academy of Interactive Arts and Sciences (AIAS) Computer Role Playing Game of the Year finalist).

"You get to do more of the fun, exciting high-level AI when you don't have to worry about tangled power cords and broken axles."

Davis accepted a guest professorship at MIT this past fall and is also active in the game community, serving as an advisor to trusted industry publishers and as a peer panel leader for the AIAS. Now a resident of Massachusetts, Davis reminisces about "getting baseball tickets at the last minute" as a student in Pittsburgh, "Try that in Boston!"



APARNA JAIYA

B.S., Computer Science
Carnegie Mellon University, 2004

Using her father's formula of "99 percent perspiration and one percent good luck," Aparna Jaiya graduated from Carnegie Mellon not only with a broad knowledge of computer science, but also a broad understanding of her own capabilities. Today she is a Technology Analyst for Goldman Sachs & Company in New York City.

"Carnegie Mellon taught me how to use computer science as a tool to solve complex business problems in various walks of life — from the trading desks' requirements at work (designing a Zero Coupon Swaps trading system within a week), to those at home (designing the optimal model mortgage loan portfolio for buying real estate)."

Aparna's multi-faceted life includes running marathons, Indian classical dancing and mentoring high school students preparing for college.

the Power

Building the Panama Canal took 20 million man hours and over three decades to complete.

Constructing the Empire State Building took seven million man hours and a little more than a year.

By aggregating workers, much can be accomplished in a short span of time. The average video gamer plays roughly seven hours a week. Multiply that by millions of gamers around the world, and you have an enormous amount of brainpower at work.

“Luis’ wonderful idea was to harness all of this brainpower by inventing online games-with-a-purpose,” says his advisor, SCS Professor Manuel Blum.

Luis von Ahn, Ph.D. (CS’05) and Blum focused on harnessing human time and energy for addressing large-scale computational problems that computers cannot tackle on their own. One result is The ESP Game, a fast-paced two-player online game. It’s not only fun to play but also serves to bridge the cognitive divide between humans and computers. By creating games that leverage people skills, humans can work for computers, rather than the other way around.

The goal of ESP is to improve online image searches by indexing and labeling the roughly two billion images available on the Internet, a monumental task that would take 10 people working around the clock more than 350 years to accomplish.

Current search engines are often inaccurate because they rely on the image file name and the text surrounding it to make an educated guess about what is in the picture.

With ESP, the fun – and the work behind it – begins with the pairing of anonymous Internet partners for a two and a half minute session. Both players see the same image and type in words to describe it: man, hat, dog, bowling ball, etc. They win points and move onto the next image when they match words. More matched words equals more points for the players, and more data for von Ahn: each matched word set produces a label for that particular image.

In addition to improving image searches in general, ESP’s labels have the potential to help Internet users block inappropriate images, such as pornography, and to improve Web accessibility for visually impaired individuals.



The process of designing a game like ESP is much like the process of designing computer algorithms, von Ahn explains. The game itself needs to be proven correct and enjoyable, its efficiency can be analyzed and more efficient games can supercede less efficient ones. Instead of using a silicon processor, these ‘algorithms’ run on a processor consisting of humans interacting with computers over the Internet. ESP’s algorithm appears to be working rather well. More than 13 million image labels have been collected since the game debuted in 2003, with some people playing more than 40 hours a week.

Peekaboom is another von Ahn game-with-a-purpose. It builds on the data collected by ESP and is designed to enhance artificial intelligence by teaching computers how to locate objects within images.

“If I showed you a picture of just an elephant’s trunk, you might have no idea what it is. You’d probably need to see some of the elephant, too,” explains Blum. “The wonderful thing about Peekaboom is that it reveals the pixels needed in order to teach a computer to recognize the trunk.”

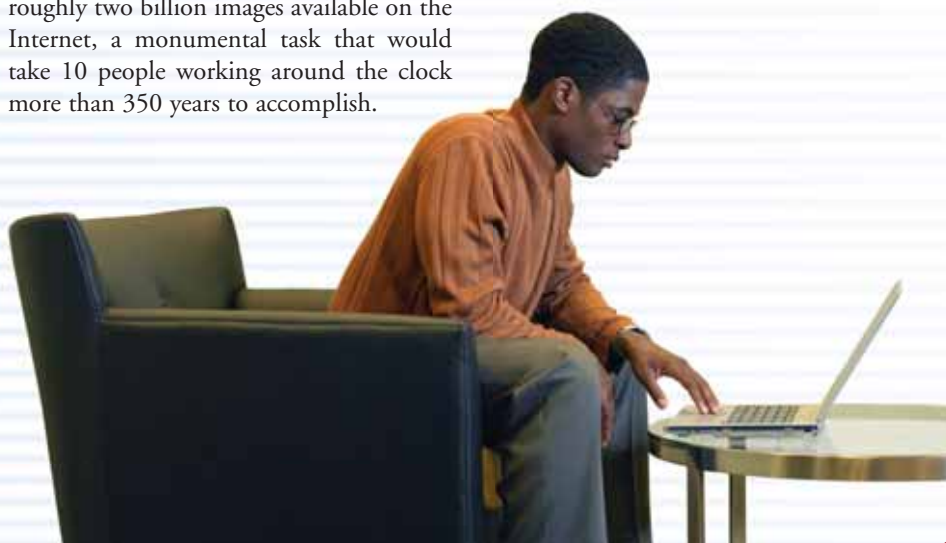

of Humans



< LUIS VON AHN >

As in ESP, Peekaboom players are paired anonymously, but this time for a four minute session and they play different roles: 'Peek' starts with a blank screen, while 'Boom' starts with an image and a word related to it. The goal is for Boom to reveal parts of the image, through circular clicking, so Peek can guess the associated word. The correct answer earns the players points and then they switch roles for the next image. Boom can also give Peek hints by "pinging" the image—ripples appear on Peek's screen to disambiguate the trunk from the rest of the elephant.

Since its launch in August 2005, Peekaboom has been played by thousands of gamers and has collected millions of data points. "Some people have spent more than 12 hours a day playing," says von Ahn, "and while they're having fun, we're collecting valuable image metadata, such as which pixels belong to which object in the image." This data could be applied toward constructing more accurate computer vision algorithms, which require massive amounts of training and testing data not currently available.

According to Blum, when it comes to using brainpower to close the cognitive gap between humans and computers, few human beings compare with von Ahn. "This is just the beginning," he says, "Luis is constantly coming up with new ideas." Δ

End Note: Luis von Ahn is currently in licensing discussions for these playfully addictive games.



Robots Around the World

You can find Carnegie Mellon robotic technology and expertise everywhere from inside coal mines to the reaches of outer space. Here's just a sample:



Autonomous Helicopter

Houghton Crater, Devon Island, NWT, Canada; 1998
Flight 93 crash site, Somerset County, Pennsylvania; 2001

Aerial mapping
www.cs.cmu.edu/afs/cs/project/chopper/www



Dante II

Active volcano at Mt. Spurr, Alaska; 1994

Eight-legged exploration robot
www.ri.cmu.edu/projects/project_163.html



Tank LeFleur

Carnegie Mellon University; 2005

Roboceptionist at Newell-Simon Hall
www.roboceptionist.com



GRACE

Edmonton, Alberta, Canada; 2002
Social Robot, completed AAAI Robot Challenge
Pittsburgh; 2005

Council for the Advancement of Science Writing
www.cs.cmu.edu/~reids/challenge



Groundhog

SW Pennsylvania; 2003

Robotic inspection and mapping of subterranean spaces
www.cmu.edu/cmnews/030625/030625_minemap.html



Explorer

Binghamton, New York; 2005

Teleoperated long-range untethered video-inspection of live distribution gas mains
www.rec.ri.cmu.edu/projects/explorer



RoboCamp West

Carnegie Mellon West; 2006

Seven week summer class (12 units college credit)
<http://west.cmu.edu/>



UltraStrip

Carnival Cruise Lines

Self-propelled paint scraper for large ships
www.rec.ri.cmu.edu/projects/ultrastrip/



H1ghlander & Sandstorm

Primm, Nevada; 2005

Autonomous vehicle race
www.redteamracing.org



Zoë

Atacama Desert, Chile; 2005

Field testing for robotic astrobiologist
www.frc.ri.cmu.edu/atacama/zoe_html



DepthX

Zacatón Cenote, NW of Tampico, Mexico; 2005

Initial field trials for autonomous underwater explorer
www.ri.cmu.edu/projects/project_544.html



Hyperion
Devon Island, NWT, Canada; 2001

First sun-synchronous navigation
http://www.ri.cmu.edu/projects/project_383.html



Mars Rover
Mars; 2005

Joseph Carsten (CS'05)
Antonio Diaz-Calderon (E'93, CS'00)
Andrew Johnson (CS'95, '97)
P. Chris Leger (CS'94, '97, '99)
Rich Madison (CS'93, '97)
Mark Maimone (CS'87, '96)
Larry Matthies (CS'87, '90)
Henry Stone (CS'81, '83, '87)
Ashley Stroupe (CS'00, '03)
Ashitey Trebi-Ollunnu (visiting researcher)
Rich Volpe (S'86, '90)
Reg Willson (CS'88, '94)
Yalin Xiong (CS'93, '95)

<http://marsrovers.jpl.nasa.gov/home>



Pearl
INDEX Awards, Denmark; 2005
CAST, Washington, D.C.; 2005

Nursebot
<http://peopleandrobots.org/pictures>



Pioneer
Kiev, Ukraine; 1999

For evaluating sarcophagus around the Chernobyl reactor
<http://www.frc.ri.cmu.edu/projects/pioneer>
<http://news.cs.cmu.edu/Releases/demo/29.html>



AIBO Robots
Fukuoka, Japan; 2002

RoboCup World Champions
www.cs.cmu.edu/~coral



Personal Exploration Robots
Augusta, Georgia and four other American sites; 2004
Aichi, Japan; 2005

Hands-on museum installations to mimic Spirit & Opportunity rovers on Mars
www.cs.cmu.edu/~personalrover/PER/



Introduction to Robot Programming
Carnegie Mellon, Qatar; 2006

<http://www.qatar.cmu.edu/>



Quasi

World's Fair for Kids, Florida; 2006
Entertainment Technology Center, Adelaide, Australia; 2006

www.etc.cmu.edu/projects/ibi
www.etc.cmu.edu/australia



DragonRunner
Operation Iraqi Freedom

Portable, lightweight reconnaissance and security robot for use by the U.S. Marine Corps
www.rec.ri.cmu.edu/projects/dragonrunner



Nomad
Mt. Erebus, Antarctica; 2000

Deployed to search for meteorites
<http://www.frc.ri.cmu.edu/projects/meteorobot2000>

Faculty Awards

Throughout 2005, many SCS faculty were recognized for their outstanding contributions to computer science.



American Association for the
Advancement of Science (AAAS) Fellow
Daniel P. Siewiorek



Association for Computing
Machinery (ACM) Fellows
Robert Harper
For contributions to type systems for
programming languages

Hui Zhang
For contributions to network architecture,
protocols and algorithms

Brad Myers
For contributions to interactive
programming environments

ACM Award: SIGCHI Academy
Bonnie E. John (HS'84, '88)



American Association for Artificial
Intelligence (AAAI) Fellow
Andrew W. Moore
For significant contributions to machine
learning, data mining and statistical AI,
and for major roles in transferring these
technologies to industry and government



Honda Prize
Raj Reddy
For outstanding achievements in computer
science and robotics, particularly as a world
leader in the study of human-computer
interaction, artificial intelligence and
speech and visual recognition by machine



Institute of Electrical and Electronics Engineers
(IEEE) Fellow
Edmund M. Clarke
For contributions to model checking
methods for formal verification



National Academy of Engineers (NAE) Member
Edmund M. Clarke
For contributions to the formal verification
of hardware and software correctness



National Science Foundation (NSF) CAREER Awards
Ziv Bar-Joseph
Modeling dynamic systems in the cell

Anupam Gupta
An algorithmic theory of metric embeddings
Dawn Song (CS'99)
Exterminating large scale Internet attacks



Presidential Early Career Award for Scientists and
Engineers (PECASE)
Russell S. Schwartz
For developing groundbreaking computa-
tional methods to describe and simulate the
self-assembly of biological structures and
cell components



Presidential Award for Excellence in Science,
Mathematics and Engineering Mentoring (PAESMEM)
Lenore Blum
For transforming the culture of computing
at Carnegie Mellon to embrace diversity as
critical for the field and future of our nation
and by creating a model mentorship organi-
zation, Women@SCS, for women students
in computer science



Sloan Fellows (2005-2007)
Anastassia Ailamaki
Karl Crary (CS'93, HS'93)
Anupam Gupta



Popular Mechanics Breakthrough Award
David Wettergreen (S'87, E'89, CS'95)
For his work on technology for robotic
exploration



Popular Science "Brilliant 10"
Doug James
For developing algorithms that reduce the
number of coordinates needed to describe
complex deformation phenomena such as
trees blowing in the wind or objects falling
to the ground

Last summer **James E. Tomayko**, SCS teaching professor and director emeritus of the Master in Software Engineering program (MSE), received the inaugural Coach Award at the MSE 15th anniversary celebration. The award, which will be presented annually, was established to recognize his many contributions to the program and the university. Sadly, Tomayko died on January 9 after a long illness. He was 56.

It's not about computers... it's about what you can do with computers.

March 15, 2006

Fifty years ago, the linked list made its debut at the 1956 Dartmouth summer workshop in the form of IPL, a list-processing programming language used to implement the Logic Theorist (LT) on the then-state-of-the-art JOHNNIAC computer. The following February, Allen Newell and J.C. Shaw presented their findings at the Western Joint Computer Conference in Los Angeles.

"In this paper we shall discuss the programming problems involved and describe the solutions to these problems that we tried in programming LT."

"Perhaps the most striking feature of LT when compared with current computer programs is its truly non-numerical character. Not only does LT work with other symbols besides numbers, but many of its computations either generate new symbolic entities (i.e., logic expressions) that are used in subsequent stages of solution, or change the structure of memory."

They needed a flexible data structure and the linked list was born:

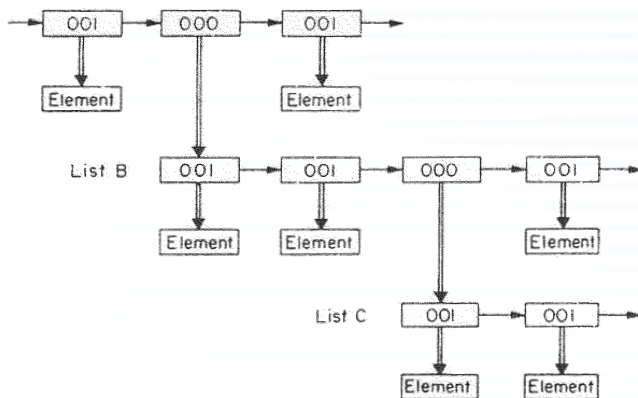

"Since a list itself is an ordered set of items which may themselves be lists, we obtain most of the flexibility we desire in the memory structure. There is no limit to the complexity of the structures that can be built up, provided that one knows how to use them, except the total memory space available."

And in 1956 they were rather limited...

"The JOHNNIAC's 4,096 words of high speed, random-access core storage is not adequate for a program and data lists [the size of LT]."

At 5 bytes per word, that's a whopping 20,480 bytes of core memory.

My, how things have changed. :-)

Visit www.cs.cmu.edu/thelink to view the 1957 WJCC papers on LT & IPL.

Tell The Link what you think.

March 25

Send your comments to TheLink@cs.cmu.edu by the end of May for a chance to win a Scottie dog blanket or a basket of Pittsburgh goodies! (Remember to include your name, address and daytime phone number.)

Carnegie Mellon

FIFTY YEARS OF COMPUTER SCIENCE



read



recall



blink



link



play



type



move



explore



learn



identify



spin



attend



JOIN THE **CS50** CELEBRATION
[WWW.CS50.CS.CMU.EDU](http://www.cs50.cs.cmu.edu)

April 20 – 22, 2006

School of Computer Science
4305 Newell-Simon Hall
Carnegie Mellon University
5000 Forbes Avenue
Pittsburgh, PA 15213

Nonprofit Org.
U.S. Postage
PAID
Pittsburgh, PA
Permit #251